

Cylindrical Electric Strike Installation Instruction & Templates ES-CY079L-32D

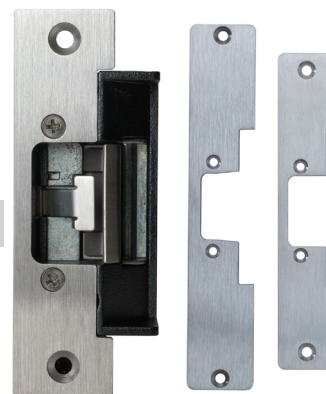

THIS PACKAGE INCLUDES:

- 1- 4 PIN power connector (12V)
- 1- 4 PIN power connector (24V)
- 1- 3 PIN door status connector
(with 'L' Models)
- 1- 3 Faceplates
- 4- Wire nuts
- 2- #10 x 1 1/4" wood screws
- 4- #12-24 x 1/2" screws
- 2- Mounting brackets
- 2- Spacers
- 1- Varistor

1. DESCRIPTION

INOX Grade 1 ANSI strikes for cylindrical locksets offer the very best strike quality and performance, with three stainless steel faceplates provided. The 'Universal' strike design delivers unparalleled application flexibility, with field selectable voltage, fail safe/fail secure operation and mechanical adjustment of the strike body.

2. SPECIFICATIONS

Voltage	12/24V AC/DC
Current Draw	260mA@12V DC 150mA@24V DC
Static Strength	1,500 Lbs.
Dynamic Strength	70 Ft-Lbs.
Endurance	1,000,000 Cycles (Factory Tested) 250,000 Cycles (UL Verified)
Mode	Field Selectable Fail Safe/Fail Secure
Mech. Adjustment	Strike Body/Faceplate
Operation	AC-Buzz, DC-Silent
Duty	Continuous
Latch Bolt Monitor	SPDT, 100mA @ 24V DC
Dimensions (Body)	ES-CY1079L: 3 3/8" H x 1 3/4" W x 1 7/32" D (86mm x 44mm x 31mm)

UL 294 Performance Levels

- Line Security = Level I
- Attack Level = Level I
- Endurance Level = Level IV
- Standby Power = Level I

3. DIMENSIONS

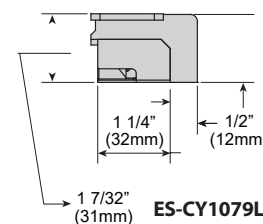
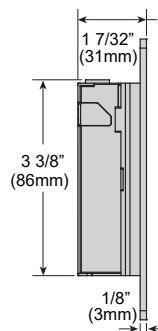
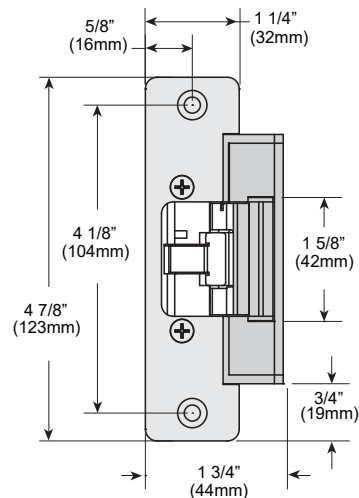

ES-CY1079L

4. INSTALLATION

1. Prepare the door jamb as per the appropriate drawing.
2. Install mounting brackets to jamb using 12-24 x 1/2" screws and pressed metal nuts. Do not tighten.
3. Spacers are used to assure flush final assembly of faceplate into jamb. Add one or more spacers between jamb and mounting bracket when face plate extends beyond the jamb. When the faceplate sits inside the jamb, spacers must be added between the mounting bracket & the lip bracket.

Make sure the clearance hole in the spacer aligns with the hole in mounting bracket.

4. Connect wires coming from the low voltage side of the transformer to wires (black) from strike.
5. Install electric strike jamb by attaching with # 12-24 screws and lockwashers.
6. Tighten secure 12-24 x 1/2" screws holding mounting brackets to jamb.

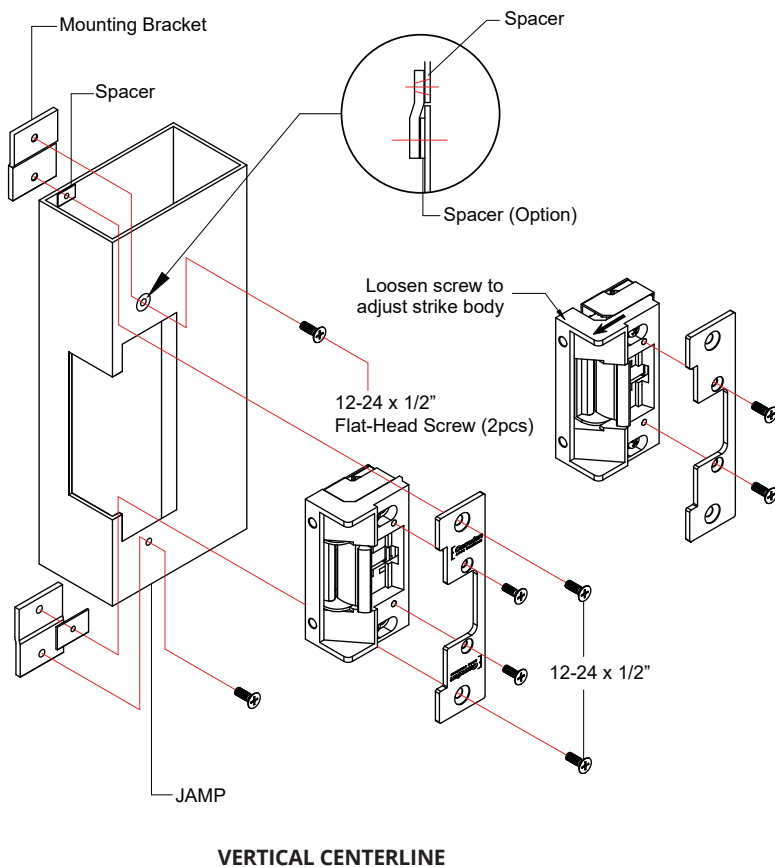

Note: The products are intended to be installed in accordance with the installation wiring diagram, mechanical assembly drawings provided with each product, the local authority having jurisdiction (AHJ) and the National Electric Code, NFPA 70. When installed in fail secure mode, the local authority shall be consulted with regard to the use of possible panic hardware to allow emergency exit from the secure area.

The electric door strike shall be installed in such a way and in such a location so as to not impair the operation of an emergency exit device or panic hardware mounted on the door.

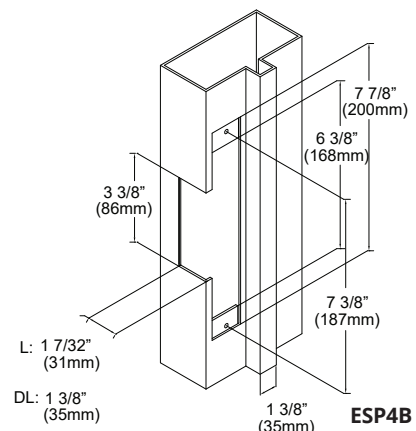
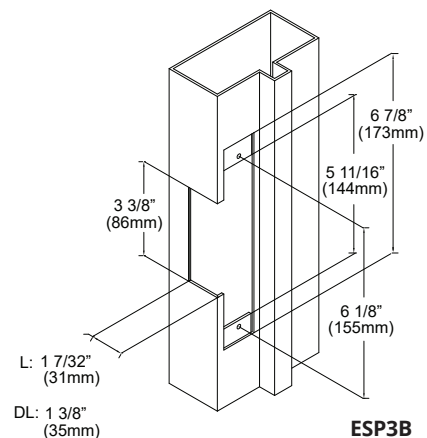
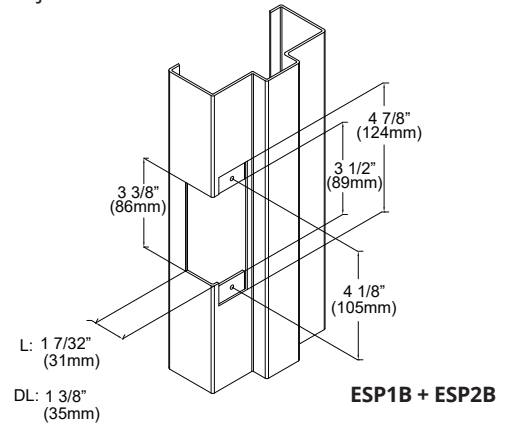

5. CONNECTIONS

POWER

12V AC/DC

Red/Black: +12V
Blue/Green: Ground

24V AC/DC

Red: +24V
Black/Blue: -
Green: Ground

A varistor is provided to protect/prevent strike from spikes. Connect varistor between input wires.

Note: For UL294 / UL1034 compliance the door strikes are to be powered via a UL294 / UL603 class 2 power limited output from a control panel and or power supply. Furthermore, when powered by AC/DC the units shall use a UL regulated UL294 / UL603 power limited class 2 output rated 12/24V with AC on indicator.

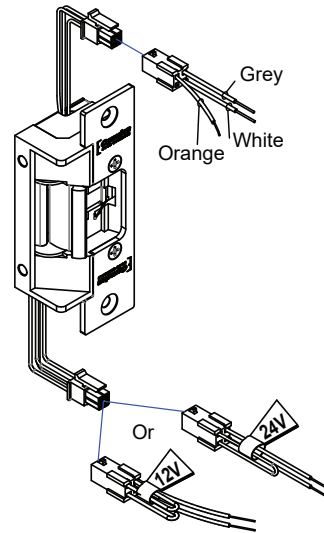

FOR CUT WIRES

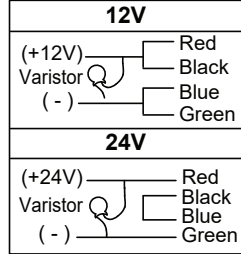

Door Status Sensor (Closed position)

With 'L' Models

White = N/O

Grey = N/C

Orange = COM

6. OPERATION

How to modify fail-safe to fail-secure or vice versa.

- (1). Loosen the screw as per the product diagram below.
- (2). Rotate the set plate 180° and slide the plate until it is properly seated.
- (3). Tighten the screw.

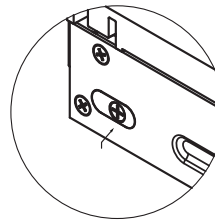

FAIL SAFE

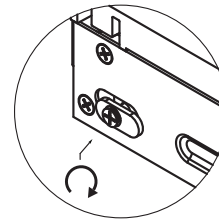

CHANGING

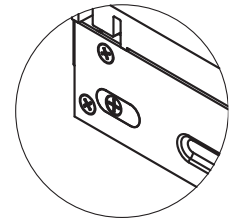

FAIL SECURE

6. FACEPLATES

INCLUDED IN PACKAGE

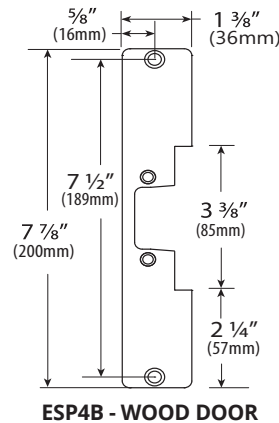
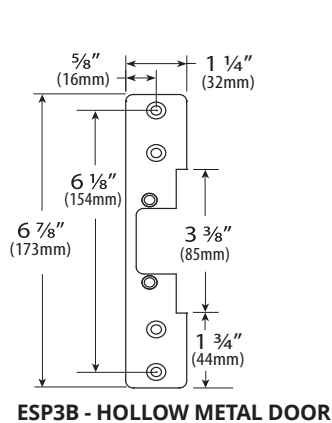
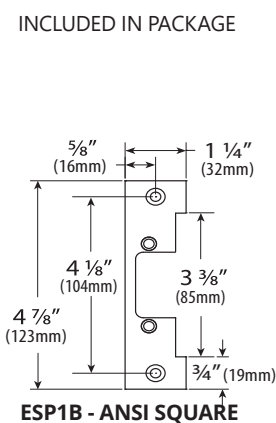

ADDITIONAL FACEPLATE

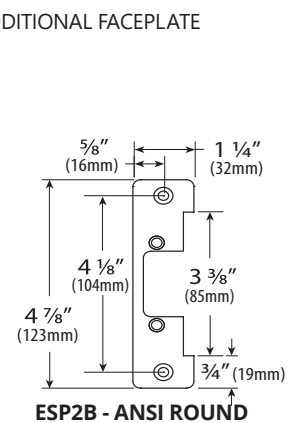

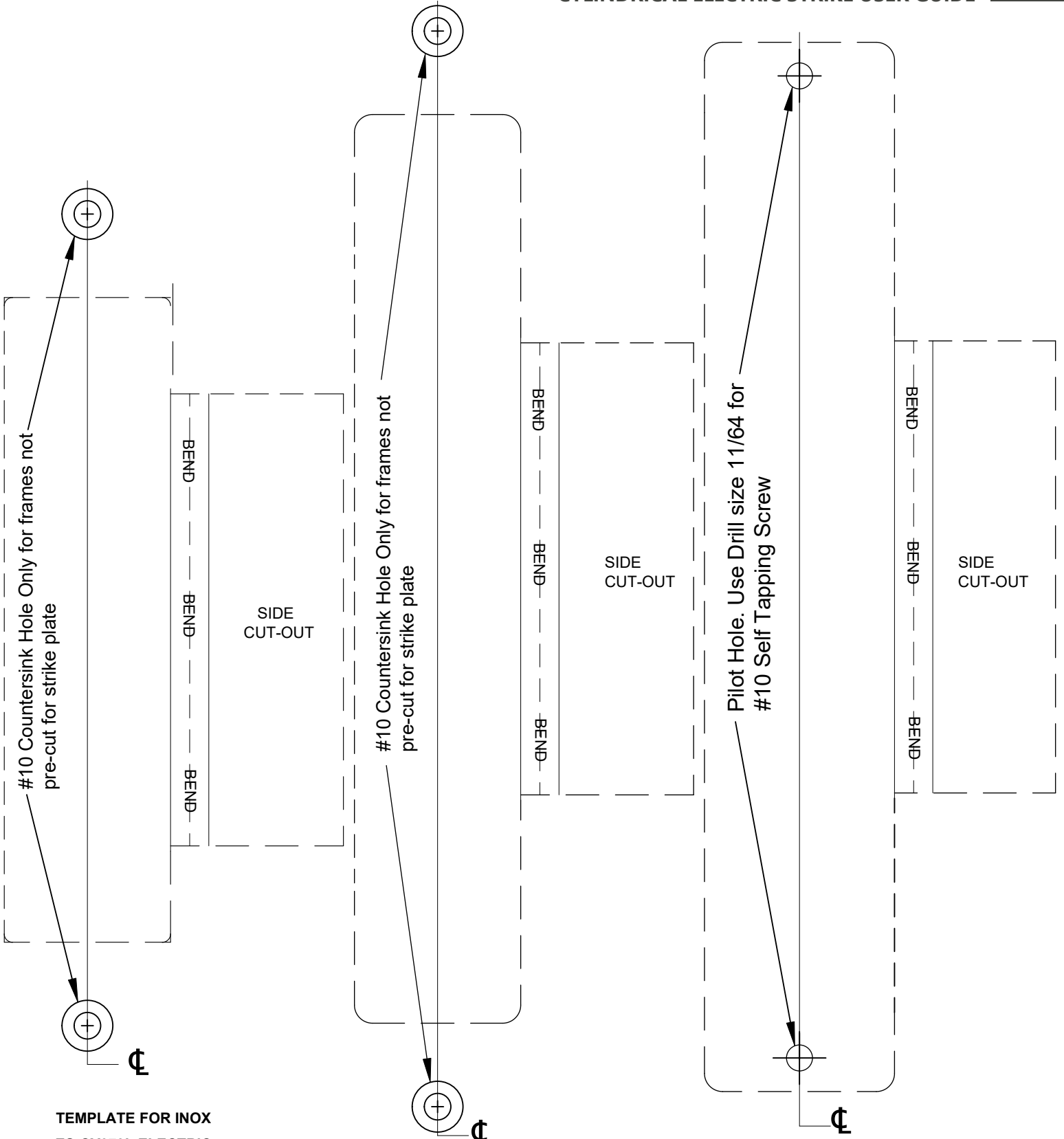

**TEMPLATE FOR INOX
ES-CY079L ELECTRIC
STRIKE**

ANSI SQUARE OR ROUND
(ESP1B & ESP2B Faceplates)

**TEMPLATE FOR
INOX ES-CY079L
ELECTRIC STRIKE**

HOLLOW METAL DOOR
(ESP3B Faceplate)

**TEMPLATE FOR
INOX ES-CY079L
ELECTRIC STRIKE**

WOOD DOOR
(ESP4B Faceplate)