

INOXSmart **INOX**
www.inoxproducts.com

Installation Instructions

**Smart Tubular Interconnect
IST with SFK Plate**

PM-ISIST6500
V20241030

Components List

Inside Trim
Inside Cover Plate
Installation Plate w/
Mounting Bracket at
4" CTC or 5-1/2" CTC
Outside Trim Plate

Strike
TL4 Tubular Latch
Strike
BT Deadbolt Latch

Collar
Thumbturn
Weather Gasket
Outside
Weather Gasket
Inside

Cylinder
Allen Key
Release Key
Metal Door DPS
Metal Jamb DPS

M5x50mm
Machine
Screws
M4x35mm
Machine
Screws
M4x20mm
Machine
Screws
Wood Door DPS
Wood Door DPS

Step 1: Changing Latchbolt Handing

The TL4 Latch has a 28-degree retraction.

Determine the appropriate door handing for the latch and remove the INSIDE washer (privacy pin side). Rotate the latch and the faceplate 180 degrees.
NOTE: Be sure to install the latch with faceplate attached to the latch body.

Center Line

Ensure the center line on the back of the faceplate meets the center seam of the latch case.

Ensure the latch has the ARROW facing up.

Step 2: Review CTC Options

4" CTC Outside Cover Plate with 5-1/2" Inside Cover Plate

5-1/2" CTC
4" CTC

Hole for Wire
4" CTC

Step 2: Review CTC Options (Cont.)

5-1/2" CTC Outside Cover Plate with 5-1/2" Inside Cover Plate

5-1/2" CTC
5-1/2" CTC

Hole for Wire
5-1/2" CTC

Step 3: Installing Latches

The deadbolt latch will be placed in the upper hole prep, while the TL4 latch will be placed in the lower hole prep.

Attach the faceplate with the provided screw packs using a Phillips screwdriver.

Step 4: Installing DPS [OPTIONAL]

NOTE: Door Position Sensor [DPS] is optional, ignore this step if not installed on wood or metal doors.

Thread the wire into the hole opening of the door, pull it from inside of the door through the opening of the door prep.

WOOD FRAME **METAL FRAME**

NOTE: Door Position Sensor [DPS] is optional, ignore this step if not installed on wood or metal frame.

Use the screws provided and install the strike plates for the deadbolt and latch.

Step 5: Install Weather Gaskets [OPTIONAL]

Ensure the 4 tabs on the weather gasket catch the edges of the sub-rose and then again on the mounting plate.

Step 6: Mounting Outside Escutcheon

Pass the wire from the outside escutcheon through the top prep hole and underneath the deadbolt. The interlocking bracket inserts into the bottom hole, and the lever spindle inserts into the tubular latch.

Step 7: Interior Sub-Plate and Aligning the Mounting Bracket

Pass the wire from the outside escutcheon through the rectangular wire hole in the interior sub-plate.

OPTIONAL: Insert the DPS wire through the hole and pull the wire through the inside trim side above the latch.

Align the two mounting bracket posts with the tubular deadbolt latch. Ensure that the metal interlocking bracket on the interior sub-plate is properly aligned with the metal interlocking bracket on the exterior plate.

Step 8: Secure Sub-Plate to Door

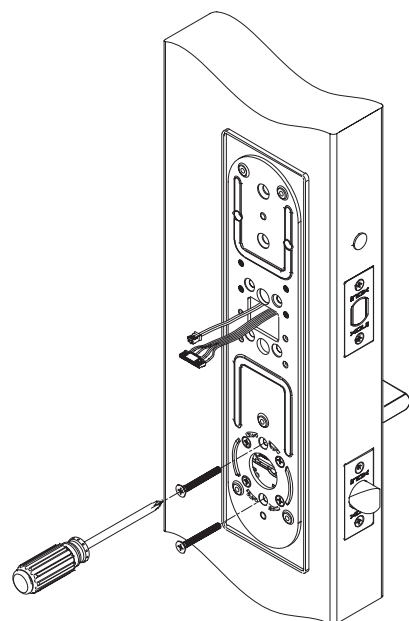

Partially screw in the top and bottom thru-bolt to the outside escutcheon plate. Throw the deadbolt to ensure that the deadbolt can be retracted.

Once both tubular deadbolt and tubular latch bolt are properly aligned, fully tighten the screws with the screwdriver.

Step 9: Installing RIM Cylinder

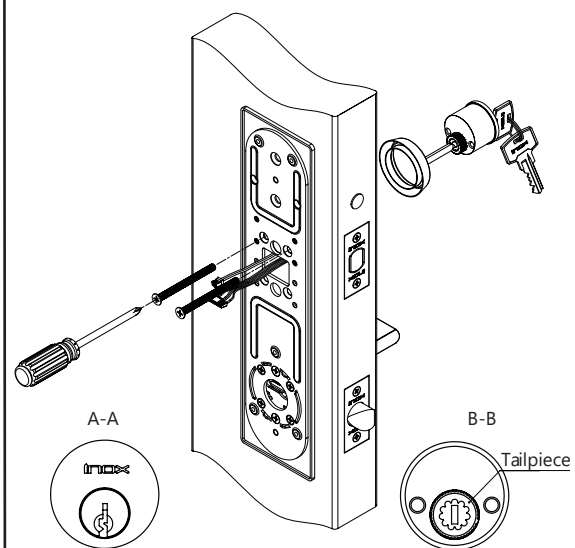

Pass the cylinder through the provided collar and thread the cylinder into the outside escutcheon. Make sure that the cylinder is orientated so that the mounting holes are positioned low as shown. Screws to secure the cylinder in place will pass through the interior sub-plate to tighten into position. Once cylinder is secured, test the alignment by using the key to throw and retract the tubular deadbolt.

The key slot on the cylinder should be in the lower off-center position. See Section A-A.

Set the outside tailpiece to the vertical position WITHOUT using the keys. See Section B-B.

Step 10: Connect Wire to Interior Trim

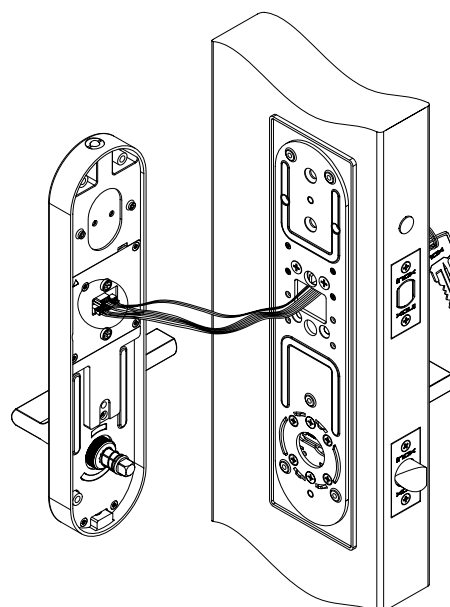

Firmly plug the wire into the socket of the inside plate. There is an audible "click" when the wire is properly inserted.

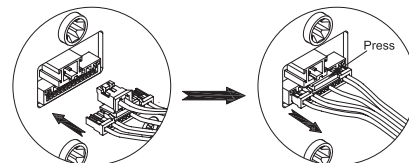

Step 11: Mounting Interior Trim

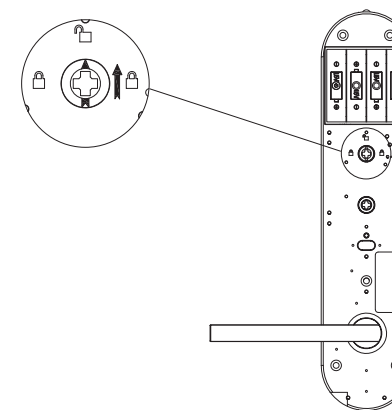

Turn the arrow of the inside plate spindle to the unlocked icon position as shown. The arrow on the spindle should point up.

Step 12: Mounting Interior Trim (Cont.)

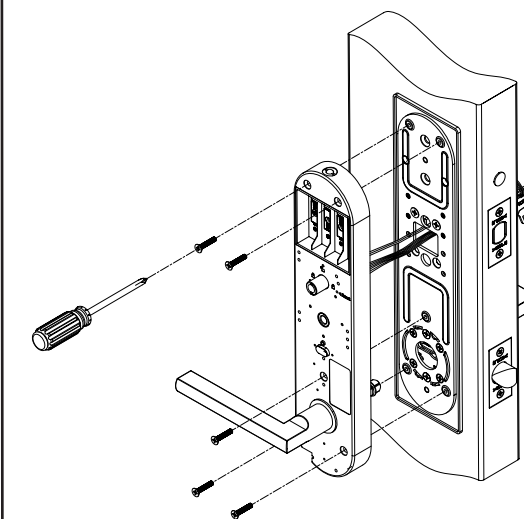

Pass the wire through the hole of the sub-plate into the door before mounting the inside plate.

Insert and tighten the five M4x20mm screws to the sub-plate. Rotate the thumbturn post, so that the arrow is pointing left or right towards the locked icon.

NOTE: Make sure to pass the wires through the wire hole and into the door before tightening the sub-plate to avoid pinching or cutting the wire with the sub-plate.

WARNING: Motor initial setting requires deadbolt to be in the retracted position.

Step 13: Installing Batteries

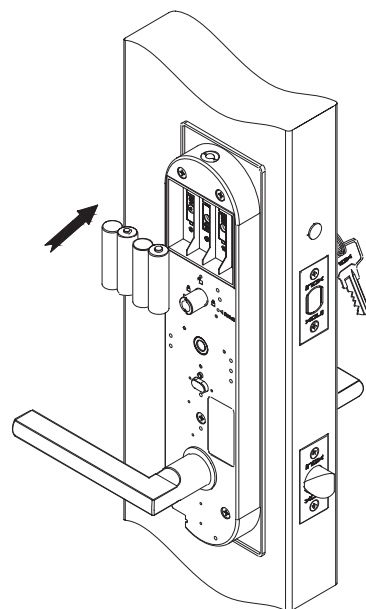

Ensure that the deadbolt is in the retracted position before installing the four (4) AA batteries. Align the batteries to the correct polarity in the compartment.

NOTE: After a short delay, the lock will activate with audio and light confirmation.

Step 14: Mounting Interior Plate Cover

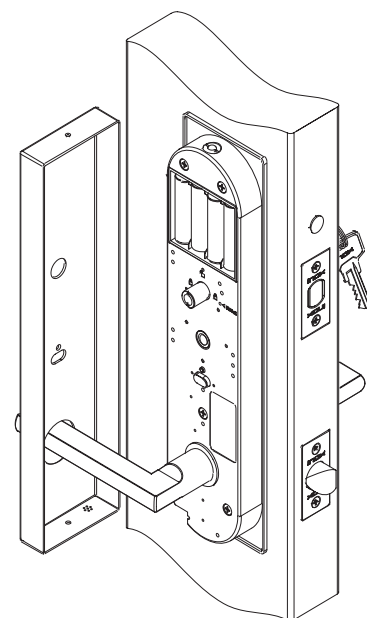

Slide the interior cover plate over the lever, push it onto the inside sub-plate and click the interior cover plate into place. Ensure the cover plate is securely attached by the ball bearing on top of the escutcheon.

When the batteries are low or need to be replaced, first remove the thumbturn from the inside escutcheon, then slide the cover plate over the lever to access the batteries pack. Replace all four (4) batteries at the same time.

Step 15: Installing Thumbturn

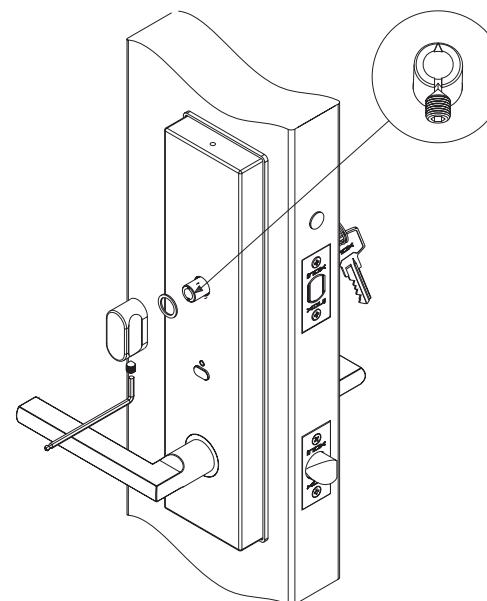

Place the clear washer onto the thumbturn hub. Align the thumbturn set screw to the groove of the spindle. Tighten the set screw using the Allen Key.

Step 16: Tightening Levers

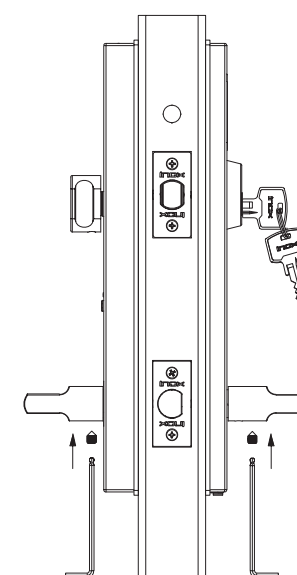

Secure the levers on both sides of the door by tightening the set screws with the Allen Key.

